

Collectie
2024 – 2025

Collection
2024 – 2025



LABEL
VANDENBERG

Meubelen die
met je meeleven

Furniture that
lives with you



Collectie 2024 – 2025

Collection 2024 – 2025

Ons verhaal Our story	3
Fauteuils Armchairs	13
Stoelen Chairs	51
Sofa's Sofas	77
Outdoor Collection	97
Collectie Collection	106
Innovatie, Reparatie & service Innovation, repair & service	110
Colorbox	111
Index	112



Ons verhaal
Our story

Ton Marieke Gerard Jasper



Familie van den Berg The Van den Berg family

Wij zijn een Brabants familiebedrijf dat al drie generaties unieke, handgemaakte meubelen maakt van natuurlijke materialen. Gerard en Ton van den Berg groeiden op in de meubelfabriek van hun vader. Zijn hartstocht voor het vak bleek besmettelijk.

Marieke (dochter van Ton) en Jasper (zoon van Gerard) vormen de derde generatie die vindt dat meubelen maken nog steeds een ambacht is.

Als familiebedrijf begrijpen wij hoe intiem je eigen huis is. We zijn blij dat we bij je binnen mogen komen. Onze zitmeubelen zijn gemaakt om te blijven en om lang waarde toe te voegen aan het meest waardevolle wat je hebt: thuis.

We are a family business based in Brabant that has been producing unique handmade furniture from natural materials for three generations. Gerard and Ton van den Berg grew up in their father's furniture factory. His dedication to the profession proved to be contagious.

Now Marieke (Ton's daughter) and Jasper (Gerard's son) are the third generation to believe that furniture making is still a craft.

As a family business, we understand the intimacy of your own home. We are happy to visit you. Our chairs and sofas are made to last and to add value to the most precious thing you have: your home.



Rick
Marlous
Kimm
Anita
Carola
Debby
Marscha
Leny
Jeannet
Karin
Loan
Annick



Ons verhaal
Our story



Kemal Mariska Alpha Feyzullah Stan Michel Julia Corne Tristan



Uitgebreide familie
The extended family

Het is zo
mooi om
iets te
maken wat
uniek is.

LABEL Vandenberg

Ons verhaal Our story

Het is zo mooi om iets te maken
wat uniek is.

Dat begint al met het materiaal.
Wij werken met natuurlijke materialen,
en die zijn altijd anders. Een beetje
zoals mensen zelf. De imperfectie
maakt het voor ons net interessant.
Hout, leer en stof... naarmate de
tijd verstrijkt, gaat het meer leven.
Onze meubelen leven met je mee.

Wij weten dat comfort heel
persoonlijk is. We hebben een
studie gemaakt van zitten.
En wij raken nooit uitgeleerd.

Iets maken dat uniek is, kost wel tijd.
Als familiebedrijf zijn we gewend
om in de lange termijn te denken.
Of het nu over mensen, materiaal of
meubelen gaat: wij gaan ervan uit
dat iets voor lange tijd is.
Duurzaamheid zit in ons bloed.

Dat betekent dat we dichtbij huis
blijven. Bijna alles kan lokaal.
Wat je nodig hebt, is meestal dichterbij
dan je denkt. We maken onze meubelen
hier in onze eigen fabriek,
naast de showroom.

We werken vlakbij elkaar en we
begrijpen elkaars werk.
Onze ambachtelijke kennis is als een
levend bouwwerk waar we allemaal
aan mee timmeren. Al drie generaties
lang. De vierde generatie bouwt
ook al mee, al doen zij dat
nu nog spelenderwijs.

Wij geloven bij design dat je de pure
enkelvoudige vorm moet vasthouden.
Vanaf de eerste schets tot en met de
uiteindelijke productie.

Onze designers doen dat allemaal
op hun eigen manier. Stuk voor stuk
maken ze iets wat anders is en bij
ons past.

Ook onze manier van stofferen is
anders: onze handtekening is lossier, vrij.

Dat unieke zitmeubel kun jij vervolgens
op jouw eigen manier personaliseren.

Dat persoonlijke vinden wij belangrijk.
Persoonlijke service, persoonlijke
aandacht. We houden van mensen.
Van onze eigen mensen, maar we zijn
ook benieuwd naar jou.

Goed zijn voor elkaar vormt de basis
van een gezonde familie. Goed zijn
voor je mensen, je klanten en je
leveranciers is dan een logisch gevolg.

Om de wereld zo weinig mogelijk te
belasten, werken we volgens het
lean-principe: een manier van werken
waarbij je vooral waarde toevoegt en
zo weinig mogelijk verspilt.

Want we zijn trots op ons verleden,
maar we houden nog meer van
de toekomst.

It's so nice
to make
something
that is
unique.

LABEL Vandenberg

Ons verhaal Our story

It's so nice to make something
that is unique.

It starts with the material.
We work with natural materials that
are always different. A bit like people
themselves. The imperfections are
what make them interesting.
Wood, leather and fabric... they
become more alive with time.
Our furniture lives with you.

We know that comfort is personal.
We have studied sitting.
And we never stop learning.

Creating something unique takes time.
As a family business, we are used to
taking the long view.
Whether it's people, materials or
furniture, we assume that it will
be around for a long time.
Sustainability is in our blood.

That means we stay close to home.
Almost everything can be done locally.
What you need is usually closer than
you think. We make our furniture here
in our own factory, next to
the showroom.

We work closely together and
we understand each other's work.
Our craft know-how is like a living
structure to which we all contribute.
For three generations.
The fourth generation is already
helping to build, though still in
a playful way.

We believe that design should
preserve the pure, unique form.
From the first sketch to the
final product.

Our designers all do this in their
own way. Each one creates something
that is different and that suits us fine.

Even the way we do upholstery is
different: our signature is looser and
more free.

You can then personalize that unique
chair or sofa in your own way.

This personal aspect is important
to us. Personal service, personal
attention. We love people.
Our own people, and we are also
curious about you.

Being good to each other is the
foundation of a healthy family.
Being good to your people, your
customers and your suppliers is a
logical consequence.

To minimize our impact on the world,
we work lean. It's a way of working
that focuses on adding value and
minimizing waste.

Because we are proud of our past, but
love the future even more.

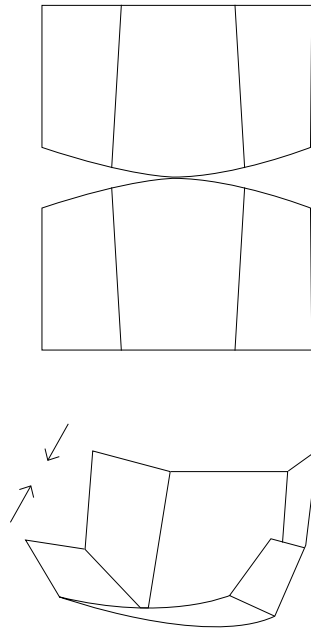

Gustav Fauteuil – Inside Fabric Farrar Stone –Outside Leather Water Buffalo Dark Grey – Swivel Base Cement Grey

Wij geloven bij
design dat je de pure
enkelvoudige vorm
moet vasthouden.
Vanaf de eerste
schets tot en met
de uiteindelijke
productie.

We believe that design should preserve
the pure, unique form. From the first sketch
to the final product.

LABEL Vandenberg

First Class

By Gerard van den Berg

Leather Bald Sprang Olive – Swivel Base Black Grey



Taboo Small Side Table

By Gerard van den Berg

Plate Grizzle Green – Legs Black Grey

Fauteuils

Armchairs



First Class

Lola

Cheo

Gigi

Gigi Soft

Tripoli

Bobo

Cocoon Lounge

Bean

Seat24

Seat24 Low

Hidde

Hidde Soft

Gustav

Fedde

etc.



Lola

By Peter van de Water

Outside Leather Rio Dark Brown – Inside Fabric Undyed Wool Brown – Swivel Base Bronze Brown
Outside Leather Bald Sprang Green – Inside Fabric Berbero Tundra – Swivel Base Bronze Brown

Cheo

By Gerard van den Berg

Leather Mammot Lead Grey – Legs Wood Tar Black

Taboo Small Side Table

By Gerard van den Berg

Plate Rusty Oak – Legs Oxide







Gigi Soft

By Gerard van den Berg

Fabric Stonewashed Linen Jade – Swivel Base Black grey ↑

Gigi

By Gerard van den Berg

Fabric Maniacu – Swivel Base Black Grey ←

Het idee
The idea

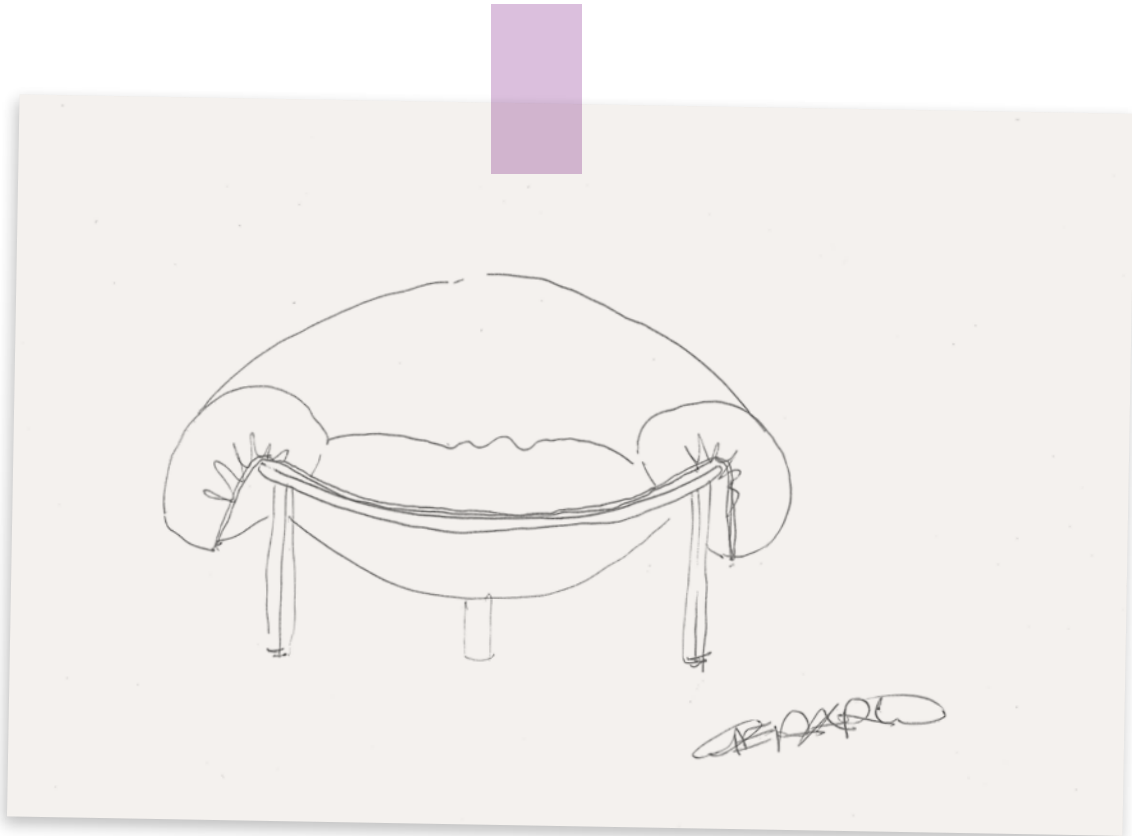

— Een groot, zacht nest, dat is de Tripoli.
Hoe je ook zit of hangt, recht of overdwers,
hoe groot of klein je ook bent, je zweeft.
De driepoot geeft zoveel beenruimte dat
iedereen zijn draai erin kan vinden.

— Tripoli is a big, soft nest.
No matter how you sit or slouch
in it, straight or diagonally, or how
big or small you are, you float.
The three legs offer so much
legroom that everyone can find
their place.

Tripoli



Gerard
van den Berg



Tripoli

By Gerard van den Berg

Leather Elite Opal – Legs Oxide ↑
Fabric Undyed Wool Grey – Legs Black Grey →





Tripoli

By Gerard van den Berg

Leather Elite Opal – Legs Oxide ← ↓



Ginny Tray

By Meike Harde

Oak Harena Hardwax sealer

Wij kiezen voor
een andere manier
van stofferen.
Onze handtekening
is lossier, vrij.

We choose to do our upholstery differently.
Our signature is looser and more free.

LABEL Vandenberg



Bobo

By Gerard van den Berg

Leather Rio Olive – Legs Bronze Brown

Cocoon Lounge

By Gerard van den Berg

Fabric Farrar Ochre — Legs Black Grey



Het idee
The idea

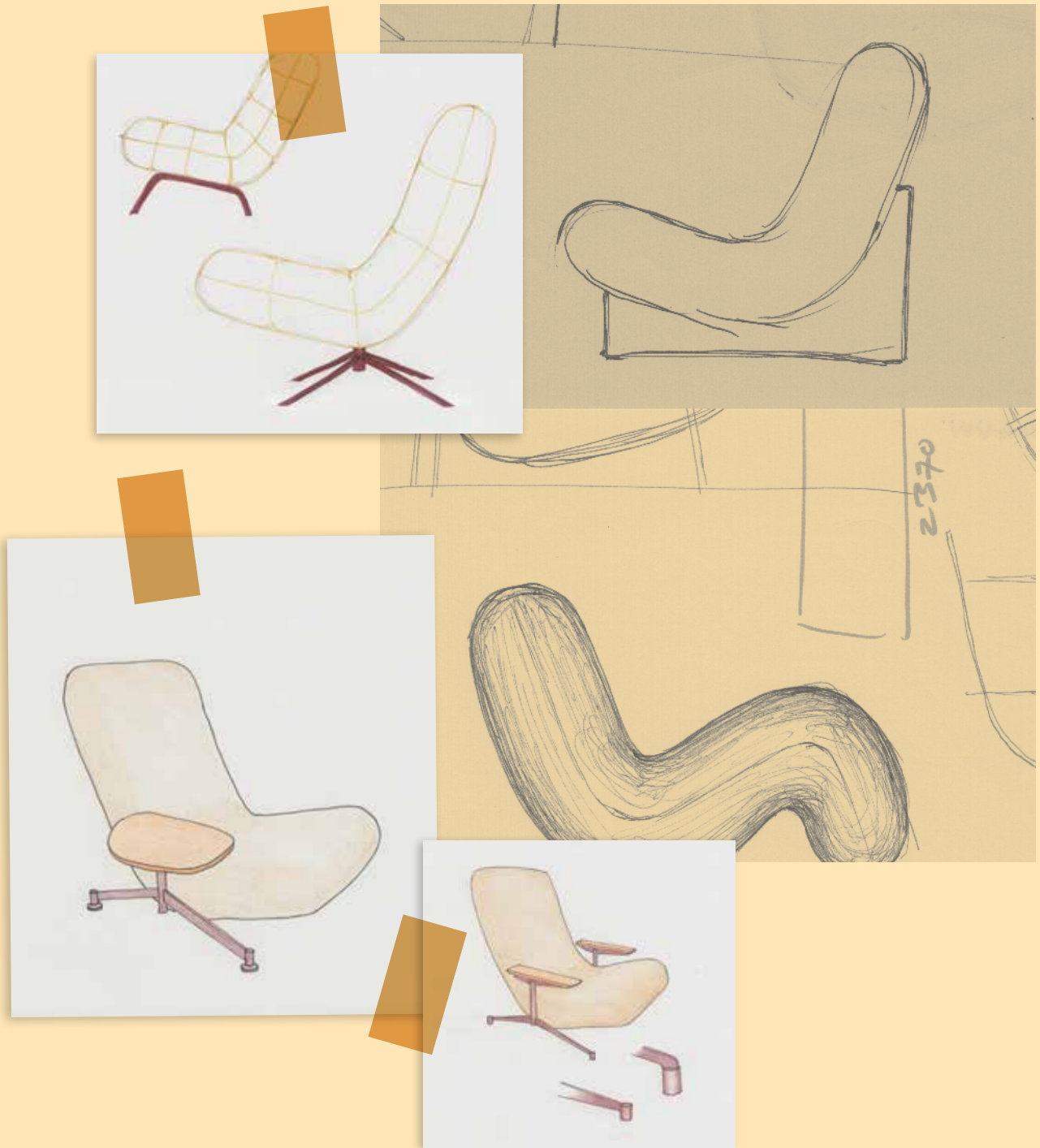

— Deze fauteuil ontstond door schetsen en spelen met vorm. Op papier ontstond een volumineuze maar elegante stoel. Daarna namen we diverse essentiële beslissingen over proportie, ergonomie, bekleding, materiaal en kleur om een comfortabele stoel te creëren. Niettemin blijft het levendige karakter van de oorspronkelijke schets zichtbaar in het eindresultaat.

— Bean was created by sketching and playing with shapes. A voluminous yet elegant chair was created on paper. We then made several key decisions about proportion, ergonomics, upholstery, material and colour, creating a comfortable chair. But you can still see the vivid character of the original sketch in the final result.

Bean



Daphna
Laurens



“We love the Dutch word ‘vormgever’, literally a person who gives shape. Giving shape to thoughts, objects, products and spaces is what we do.”

Daphna Laurens



Bean

By Daphna Laurens

Leather Elite Amber – Swivel Base Copper



Het idee
The idea



— Op een dag zat ik in het vliegtuig... op stoel 24. Ik zat lekker. Ineens was ik op een servetje een ontwerp aan het tekenen. Dit werd later Seat24. Inspiratie op zijn best!

— The design for the Seat24 armchair came about when I was sitting in an airplane seat number 24. The environment gave me inspiration for a new design that I quickly sketched on a napkin to relax during my flight.

Seat24



Gerard
van den Berg



Seat24

By Gerard van den Berg

Leather Bison Nutbrown – Swivel Base Bronze Brown



Seat24 Low

By Gerard van den Berg

Inside Fabric Soft Wash Oxide Red – Outside Leather Rio Dark Brown – Swivel Base Black Grey ↑

Het idee
The idea

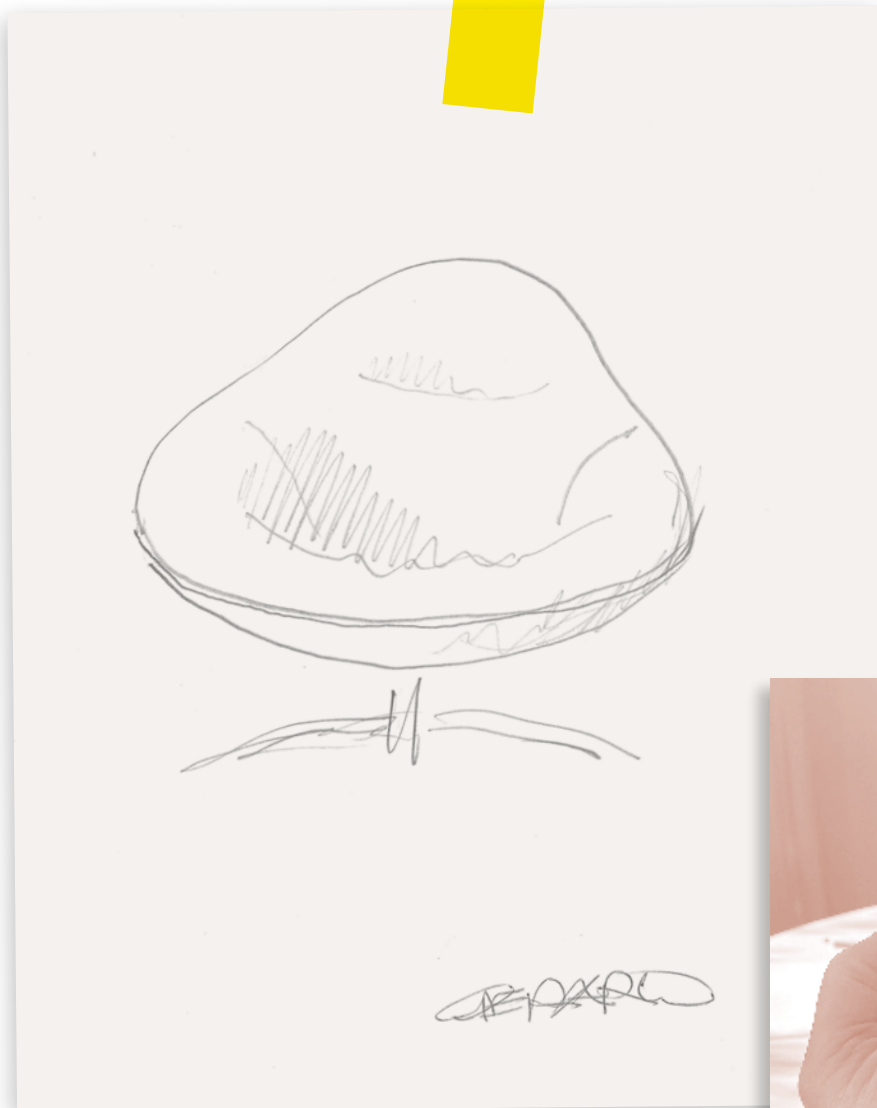

— Hidde is de naam van mijn eerste kleinzoon. De stoel is als een enorme baseballhandschoen. Hij wil je opvangen, vasthouden en koesteren en ja... hij past als een handschoen. Ga maar eens zitten...

— Hidde is the name of my first grandchild. The chair is like a giant baseball glove. It wants to catch you, hold you and cherish you and yes... it fits like a glove. Just take a seat...

Hidde



Gerard
van den Berg

Hide

By Gerard van den Berg

Leather Yak Brown – Swivel Base Black Grey





We maken het samen.
Iedereen voegt waarde toe.
Zo bijzonder.

We do it together.
Everyone adds value.
That's really special.

LABEL Vandenberg



Hide Soft

By Gerard van den Berg

Outside Leather Yak Brown – Inside Fabric Farrar Ochre – Swivel Base Black Grey

Hidde Soft



Gerard
van den Berg



Snijden
Schalmen
Stikken
Plakken
Stofferen
Inpakken

Cutting
Skiving
Stitching
Bonding
Upholstering
Packing





The Making of Hidde



Het idee
The idea

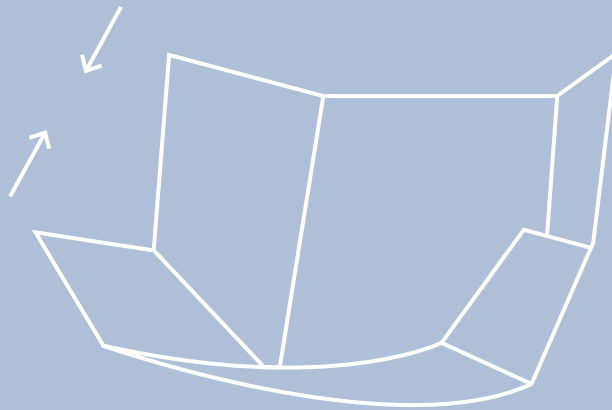
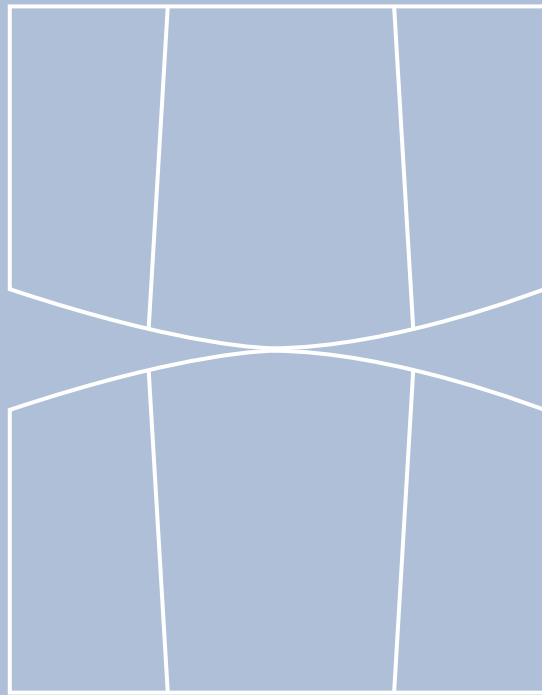

— Ik liep al jaren met de gedachte om een stoel te maken voor Vandenberg. Thuis had ik nog een oude stoel van Gerard van den Berg: een Butterfly. Het juiste idee diende zich aan toen ik een stukje karton vouwde. Met de Butterfly als basis ontstond uit mijn handen de Gustav: hoekig maar zacht.

— I had been thinking about making a chair for Vandenberg for years. At home I still had an old Butterfly chair by Gerard van den Berg. The right idea came to me as I folded a piece of cardboard. With Butterfly as a base, the Gustav chair was created in my hands: angular yet soft.

Gustav



Peter
van de Water

Gustav

By Peter van de Water

Outside Leather Water Buffalo Cognac – Inside Stonewashed Linen Nude – Swivel Base Bronze Brown





Ik ben altijd aan het schetsen.
Op enveloppen, op bierviltjes.
Daarna maak ik een klein
modelletje en dan gaat het al
leven. Ontwerpen is voor mij
knutselen, fröbelen, ik laat
mijn handen denken.

I'm always sketching. On envelopes, on beer mats.
Then I make a little model and that's when it comes to life.
For me, designing is tinkering, fiddling, letting my hands think.

Peter
van de Water

Het idee
The idea



— Fedde is rechthoekig en rond, strak en zacht. Fedde is niet op de tekentafel ontstaan maar ontworpen in de vrije ruimte. Daarom ziet Fedde er van alle kanten goed uit. Fedde is ook de naam van mijn zoon.

— Fedde is rectangular and round, smooth and soft. Fedde was not designed on a drawing board, but in open space. That's why Fedde looks good from all sides. Fedde is also the name of my son.

Fedde



Jasper
van den Berg



Als je op verschillende afdelingen werkt, ga je gaandeweg het hele proces begrijpen en wordt het vak helemaal van jou.

– Feyzullah, stoffeerderij/snijderij/plakkerij

When you work in different departments, you gradually understand the whole process and the profession becomes your own.

- Feyzullah, upholstery/cutting/bonding workshop

First Class

By Gerard van den Berg

Outside Leather Water Buffalo Cognac – Inside Fabric Kuna Naturel – Swivel Base Bronze Brown





Lola Dining

By Peter van de Water

Outside Leather Rio Olive – Inside Fabric Greta Yellow – Swivel Base Bronze Brown

Stoelen

Chairs



Lola Dining
Gustav Jr. Bar
Gustav Jr.
Tiba
Chief Low
Mali
Cocoon Bar
Cocoon Dining
Cocoon Bistro
Cocoon Bench
Orea
Orea Bar
Gabon Bar
Easy Jr.
Lola Bar
Etc.

Gustav Jr.

By Peter van de Water

Outside Leather Yak Brown – Inside Fabric Stonewashed Linen Petrol – Swivel Base Oxide →

Gustav Jr. Bar

By Peter van de Water

Leather Elite Opal – Swivel Base Oxide – Legs Oxide ↓





Avigo Folding Table

Oak whitewash hardwax sealer



Afval bestaat niet.
Wat wel bestaat is:
grondstof op de
verkeerde plek.
Lang leve
duurzaamheid.

Waste doesn't exist. What we call 'waste'
is raw material in the wrong place.
Long live sustainability.

LABEL Vandenberg





Chief Low

By Gerard van den Berg

Leather Rio Dark Grey – Legs Black Grey ↑

Tiba

By Gerard van den Berg

Leather Bison Nutbrown – Legs Black Grey ←

Tripoli

By Gerard van den Berg

Leather Elite Opal – Legs Oxide ↓



Jan Sidetables

By Jan Dijkstra

Bronze Brown



Lola Bar

By Peter van de Water

Inside Fabric Masto Black Red –
Outside Leather Bald-Sprang Brown –
Swivel Base Black Red ↴

Buck

By Chiel Janssen

Fabric Kuna 23006 – Leather Bald Sprang Dark Brown ↑

Het idee
The idea



— Hoe komt het dat de Mali en de Gabon zo comfortabel zitten? Door de losse rugleuning die met je meebeweegt. Geïnspireerd op de bekende, inklapbare campingstoel met het matje in de rug. Een matje: meer heb je eigenlijk niet nodig voor comfort.

— How is it that the Mali and Gabon chairs are so comfortable? Thanks to a loose backrest that moves with you. Inspired by the famous folding camping chair with the canvas strap in the back. A strap: that's all you really need for comfort.

Mali



Gerard
van den Berg



Cocoon Bar

By Gerard van den Berg

Fabric Stonewashed Linen Jade – Legs Black Grey



Cocoon Dining

By Gerard van den Berg

Fabric Stonewashed Linen Militaire – Legs Black Grey

Mikado Folding Table

Oak Flamed Hardwax Sealer



Cocoon Bistro & Bench

By Gerard van den Berg

Diningchair – Stonewashed Linen Naturel – Legs Black Grey
Bench – Stonewashed Linen Brick – Legs Black Grey

Passion Folding Table

Walnut natural oiled



Ik weet heel goed hoe mensen
zitten en hoe een zitmeubel
moet worden gemaakt.
Mijn technische kennis vormt
een wezenlijke bijdrage aan mijn
artistieke creativiteit.

I know exactly how people sit and how
seating has to be made. My technical knowledge makes
an essential contribution to my artistic creativity.

Gerard van den Berg





Orea

By Gerard van den Berg

Leather Yak Brown – Legs Black Grey ←

Nodi Folding Table

Walnut Natural Hardwax Sealer ←

Orea Bar

By Gerard van den Berg

Leather Yak Brown – Legs Stainless Steel ↑





Gabon Bar

By Gerard van den Berg

Water Buffalo Mud — Legs Night ↑

Mali

By Gerard van den Berg

Leather Bald Sprang Naturel — Legs Black Grey ←





Wij hergebruiken alleen leer dat al een restmateriaal is. Vervolgens geven we het een nieuwe bestemming. Wij houden zo van leer. Hoe natuurlijker het materiaal, hoe mooier het met de tijd gaat leven.

We only reuse leather that is already a waste material.
We give it a new purpose. We really love leather.
The more natural the material,
the more beautifully it comes alive over time.

LABEL Vandenberg

Easy Jr.

By Peter van de Water

Leather Rio Black – Swivel Base Night



Passion Secretary

Walnut Natural Hardwax Sealer



Easy Jr.

By Peter van de Water

Leather Water Buffalo Cognac – Swivel Base Black Grey

Passion Folding Table

Oak Natural Hardwax Sealer

Lola Dining

By Peter van de Water

Inside Fabric Kuna 23013 Lila – Outside Leather Bald Sprang Dark Brown – Swivel Base Black Red →

Lola Bar

By Peter van de Water

Inside Fabric Masto black red – Outside Leather Bald-Sprang brown – Swivel Base Black Red ↓





Nodi Folding Table

Walnut Natural Hardwax Sealer ↑



Teddy

By Gerard van den Berg

Leather Rio Olive

Sofa's

Sofas



Teddy
Buck
Ginny
Moby Dick
Cocoon
Etc.

Het idee
The idea

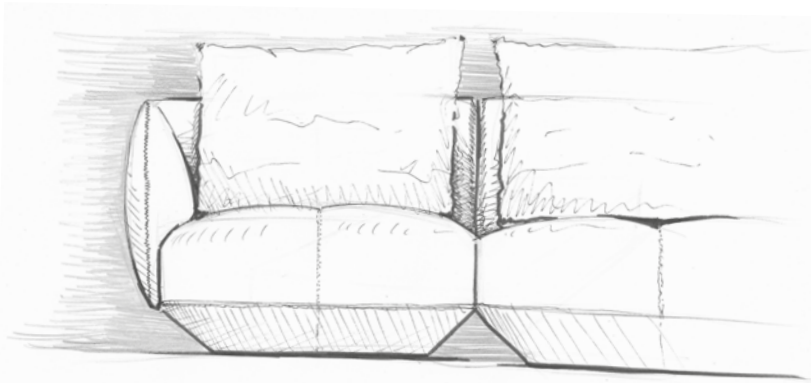
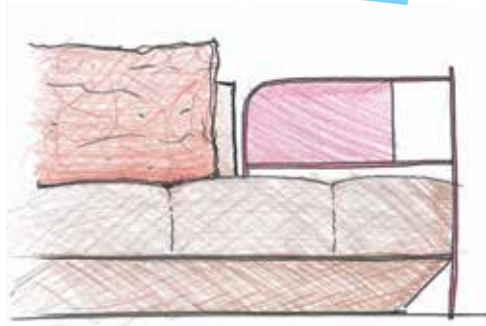

— In Indonesië zag ik eens enorme, massieve rotsen uit het water omhoog torenen. De onderkant was door watererosie rank en smal geworden, de rotsen leken te zweven. Een indrukwekkend evenwicht dat mij later inspireerde tot de modulaire Buck-banken.

— In Indonesia I once saw these huge, massive rocks rising out of the water. Water erosion had made the base narrow and slender, and the rocks seemed to float. An impressive balance that later inspired me to create the modular Buck sofa.

Buck

Modular Sofa



Chiel
Janssen



Buck

By Chiel Janssen

Fabric Masto Sand Yellow [↑](#) [→](#)

Mini Cocoon Pouf

By Gerard van den Berg

Fabric Stonewashed Linen Ochre [→](#)







Buck

By Chiel Janssen

Leather Water Buffalo Mud – Fabric Mastro Cognac



Het idee
The idea

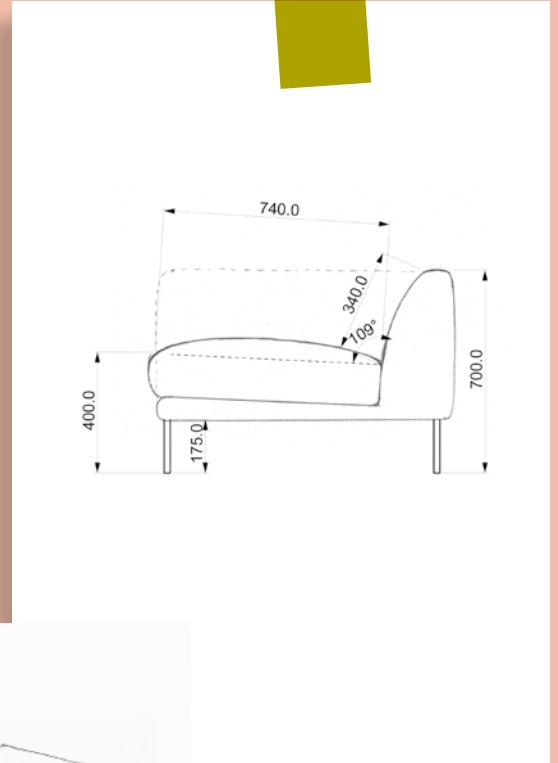

— Een bank die eigenlijk een bed is. Of een bed dat stiekem een bank is. Hoe dan ook: Ginny nodigt je uit om lekker te komen liggen. Want liggen is het nieuwe zitten.

— A sofa that is actually a bed. Or a bed that is secretly a sofa. Either way, Ginny invites you to lie down and relax. Because lying down is the new sitting.

Ginny

Modular Sofa



Meike Harde

Ginny Modular Sofa

By Meike Harde

Fabric Atohi YP16025 – Legs Night ←



Ginny Modular Sofa

By Meike Harde

Fabric Berbero Beach – Leather Water Buffalo Cognac – Legs Night

Carry Side Table

By Peter van de Water

Wood Oak – Legs Copper

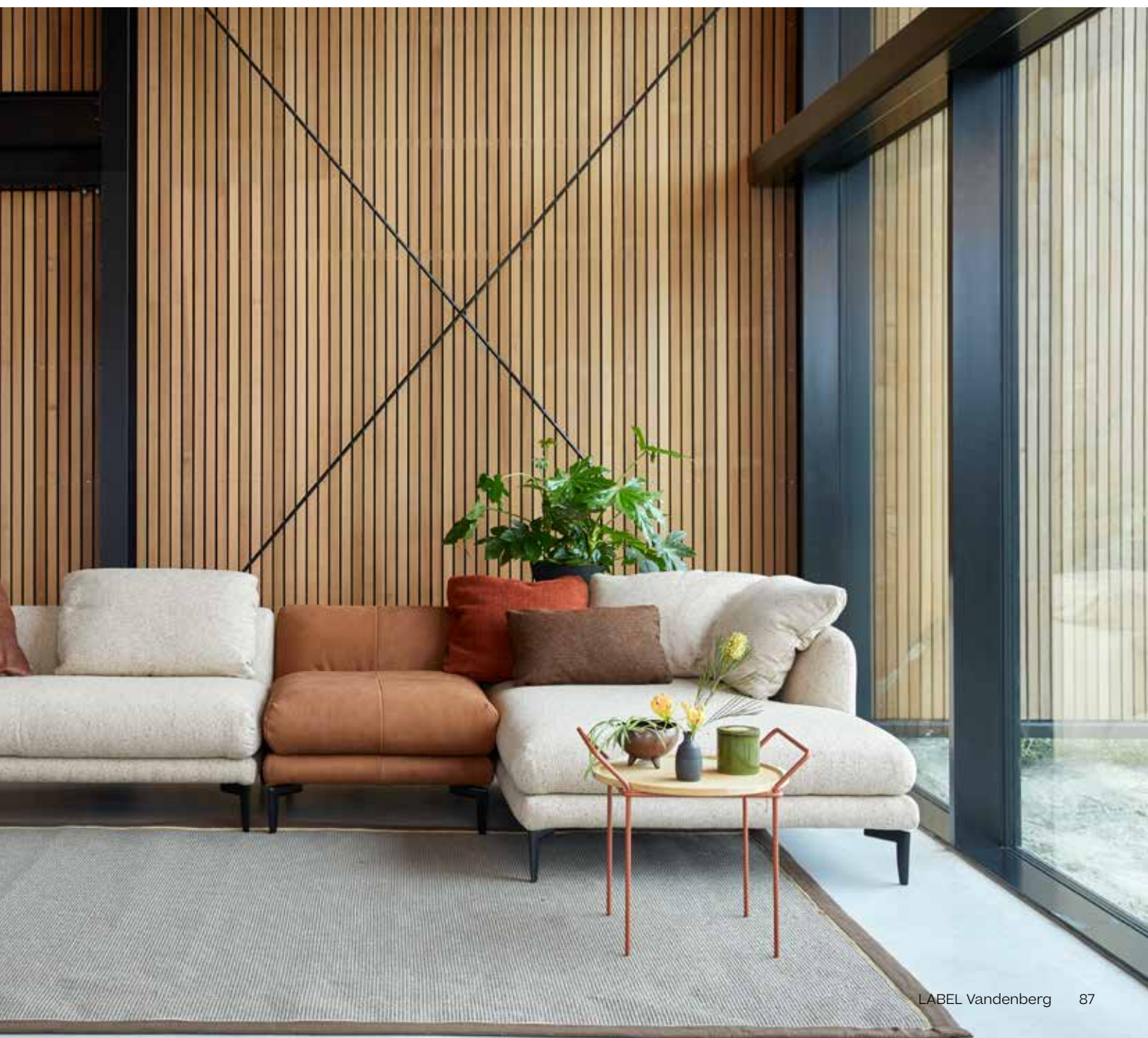



Moby Dick

By Gerard van den Berg

Leather Water Buffalo Mud – Legs Black Grey



Iets maken wat een ander niet kan maken. En vervolgens zorgen dat het heel mooi wordt. Steeds opnieuw. Ik hou zo van dit ambacht.

– Annick, stikkerij

Making something that no one else can make. And then making it really beautiful. Over and over again. I really love this craft.

– Annick, stitching

Het idee
The idea

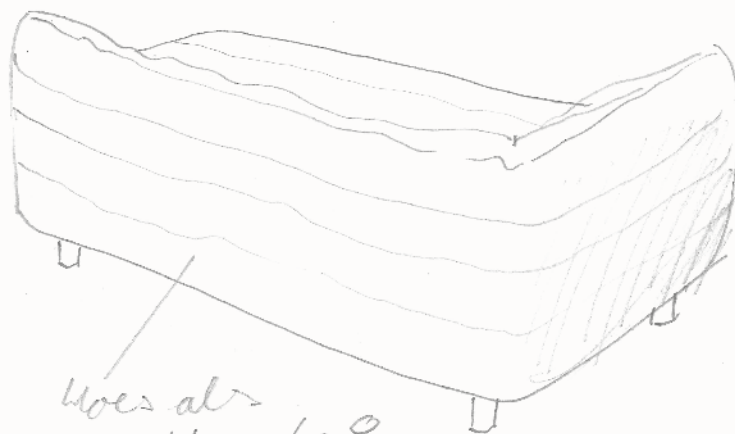

Woes als
gewatteerde jas

— Elke winter bepalen ze het straatbeeld: die dikke, doorgestikte Michelin-jassen waarin je wilt wonen. Maar... eenmaal thuis doe je die jas juist uit. Zo ontstond het idee om een zitmeubel zo'n lekkere jas aan te trekken. Een uitnodiging om thuis te blijven: dat is de Cocoon.

— Every winter they dominate the street scene: those thick, padded Michelin coats that you want to live in. But... when you come home, you take the coat off. So, the idea was born to put such a coat on a piece of furniture. An invitation to stay at home: that's Cocoon.

Cocoon



Gerard
van den Berg

Cocoon

By Gerard van den Berg

Leather Elite Opal – Legs Oxide



Jan Sidetables

By Jan Dijkstra

Bronze Brown



De bank heeft eigenlijk
een heel simpele basisvorm
maar het is de hoes die
'm zo speciaal maakt!
Ik hou van de eenvoud
van een vorm!

|

The sofa actually has a very simple basic shape,
but it is the cover that makes it so special.
I love the simplicity of form.

|

Gerard van den Berg



Gin Pouf

By Gerard van den Berg

Leather Yak Brown Embossed →

Zium Pouf

By Floris Hovers

Fabric Farrar Ochre – Petrol – Red – Leather Yak Brown



Jan Sidetables

By Jan Dijkstra

Bronze Brown





Outdoor Collection

Gustav
Koos
Gigi
Hidde



Gustav Outdoor



Peter
van de Water

Koos

By Gerard van den Berg

Recycled PVC – Legs Black Grey



**Ik hou zo van mooi weer!
Zélf s als de Gigi Outdoor
binnen staat, krijg ik een beetje
een buitengevoel!**

I really enjoy fine weather.
Even when the Gigi Outdoor is indoors,
I still get that outdoor feeling.

Jasper
van den Berg

Gigi Outdoor

By Gerard van den Berg

Fabric Bansho - Legs Black Grey





Hidde Outdoor



Gerard
van den Berg

Fabric Urunga – Legs Black Grey ↑
Fabric Paringa Black – Legs Black Grey ←
Fabric Paringa Rust – Legs Black Grey ←





Collectie/Collection
2024 – 2025

Fauteuils
Armchairs →



Bean



Bobo



Cheo



Cocoon Lounge



Don



Fedde



First Class



Foxx



Foxy



Gigi



Gigi Soft



Gustav



Hidde



Hidde Soft



Lola



Longa



Moby Dick



Seat24



Seat24-Low



Speedster

Collectie/Collection 2024 – 2025

Voor meer mogelijkheden ga naar label.nl
For more options go to label.nl

Stoelen Chairs →



Tripoli



Togo



Chief



Chief Low



Cocoon Dining



Cocoon Bistro



Easy Jr.



Gabon (activ)



Gustav Jr.



Lola



Mali (activ)



Orea



Tiba



Tonka



Cocoon Bar



Gabon Bar



Gustav Jr. Bar



Lola Bar



Orea Bar

Collectie/Collection 2024 – 2025

Sofa's Sofas



Buck Modular Sofa



Cocoon



Ginny Modular Sofa



Moby Dick



Daja (sketch)



Kameo



Santiago



Teddy

Poef Pouf



Gin



Cocoon Mini



Zium

Eetkamertafels Diningtables



Passion Folding Table



Avigo Folding Table



Mikado Folding Table



Nodi Folding Table



David Soft Folding Table

Eetkamerbank Bench



Cocoon

Collectie/Collection 2024 – 2025

Voor meer mogelijkheden ga naar label.nl
For more options go to label.nl

Outdoor Collection



Hidde Outdoor



Gigi Outdoor



Gustav Outdoor



Koos Outdoor
Table & Pouf

Bureau/secretaire Desk/secretary



Passion Desk



Passion Secretary

Dressoir Sideboard



Passion 6 doors



Passion 4 doors

Bijzettafel Sidtables



Carry



Jan Round & Straight



Taboo

Accessoires Accessories



Cushion Patch



Red Chain Carpet



Lhasa Bag

Beginnen met het einde



Beginning at the end

Innovatie en reparatie vallen tegenwoordig vaak samen: we beginnen met bedenken hoe een meubel ooit zal eindigen. En hoe we het later goed en slim kunnen repareren. Zo verlengen we de levenscyclus van onze zitmeubelen. Daarom hebben we een eigen afdeling herstoffering.

Daarnaast gaat innovatie over de materialen die je gebruikt. Wij dragen graag bij aan een circulaire economie waarbij alles hergebruikt kan worden.

Onze service gaat ook heel lang mee en is al net zo comfortabel: wij zijn altijd dichtbij.

Nowadays, innovation and repair often go hand in hand: we start by thinking about how a piece of furniture will end up. And how we can one day repair it properly and intelligently. This is how we extend the life cycle of our chairs and sofas. That's also why we have our own re-upholstery department.

Innovation is also about the materials you use. We are happy to contribute to a circular economy where everything can be reused.

Our service is also long-lasting and just as convenient: we are always nearby.

Colorbox



By
LABEL Vandenberg

Van een meubel jouw meubel maken, daar gaat het om.

Met de Colorbox kun je onze meubelen naar jouw hand zetten en in jouw eigen stijl completeren. In de Colorbox zitten verschillende kleuren hout en staal. Elke kleur geeft net een ander karakter aan het materiaal. We hebben ook bijpassende ritsen en biezen voor de modellen waarop dat van toepassing is.

Daarnaast hebben we een uitgebreide collectie van stoffen en leer om je meubel te personaliseren.

Zo passen jouw nieuwe meubelen straks volmaakt bij jou en je interieur. En zo kun je thuiskomen in stijl.

In jouw stijl.

Wil je jouw zitmeubel mee-ontwerpen? Neem contact met ons op – we zijn benieuwd naar je idee.

Making furniture your own is what it's all about.

With the Colorbox, you can customize our furniture and complete it in your own style. The Colorbox contains different colours of wood and steel. Each colour gives a slightly different character to the material. We also have matching zips and piping for the models that require them.

We also have an extensive collection of fabrics and leather to personalize your furniture. That way, your new furniture will be a perfect fit for you and your interior. So you can come home to style.

Your own style.

Would you like to help us design your chair or sofa? Get in touch – we are curious to hear your ideas.

Index

Avigo Folding Table	53, 108
Bags	109
Bean	26-29, 106
Bobo	24, 106
Buck Modular Sofa	59, 78-83, 108
Carry	87, 109
Cheo	15, 106
Chief	107
Chief Low	57, 107
Cocoon	90-93, 108
Cocoon Bar	62, 107
Cocoon Bench	64-65, 108
Cocoon Bistro	64, 107
Cocoon Dining	63, 107
Cocoon Lounge	25, 106
Cocoon Mini	81, 108
Cushions	109
Daja	108
David Soft Folding Table	108
Don	106
Easy Jr.	72-73, 107
Fedde	46-47, 106
First Class	12, 48-49, 106
Foxx	106
Foxy	106
Gabon	107
Gabon Bar	69, 107
Gigi	16, 106
Gigi Outdoor	96, 101, 109
Gigi Soft	17, 106
Gin	95, 108
Ginny Modular Sofa	84-87, 108
Gustav	10, 42-45, 106
Gustav Jr. Bar	52, 107
Gustav Jr.	53, 107
Gustav Outdoor	96, 98-99, 109
Hidde	34-37, 40-41, 106
Hidde Outdoor	96, 102-105, 109
Hidde Soft	38-39, 106
Jan Sidetables	59, 92, 94, 109
Kameo	108
Koos Outdoor	96, 100, 109
Lola	14, 106
Lola Dining	50, 75, 107
Lola Bar	58-59, 74, 107
Longa	106
Mali	60-61, 68, 107
Mikado Folding Table	63, 108
Moby Dick	88, 108
Nodi Folding Table	66, 75, 108
Orea	66, 107
Orea Bar	67, 107
Passion Folding Table	64, 73, 108
Passion Desk/Secretary	72, 109
Passion Sideboard	109
Red Chain Carpet	109
Santiago	108
Seat24	30-32, 106
Seat24 Low	33, 106
Speedster	106
Taboo	15, 109
Teddy	76, 108
Tiba	56, 107
Togo	107
Tonka	107
Tripoli	18-22, 58, 107
Zium	94, 108

Contact

LABEL Vandenberg
Ramgatseweg 5
4941 VN Raamsdonksveer
The Netherlands

+31 (0)76 572 24 50
info@label.nl
www.label.nl

Colofon

Redactie – Editorial Office

LABEL Vandenberg, Carola van Gelder

Vormgeving – Graphic Design

Studio of Things, Lenneke Heeren

Fotografie – Photography

Simone de Geus, Elisa Smook

Styling

Marianne van Heusden, Ingrid Wiendels

Tekst – Text

Luise Maria van Lieshout

Vertaling – Translation

Jane Szita

Drukwerkbegeleiding – Printing guidance

Drukwerk Unlimited, Wilbert de Jong-Coerwinkel



www.label.nl

